

CLIENT TITLE

CLIENT SER NO.

5052.072S

APPROVAL BY :

1830±50

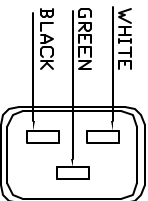
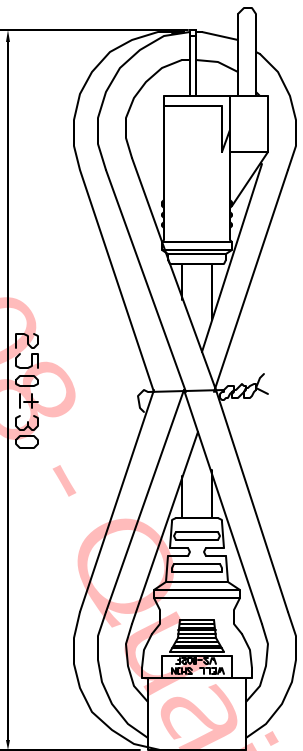
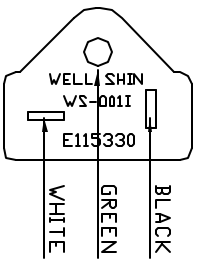
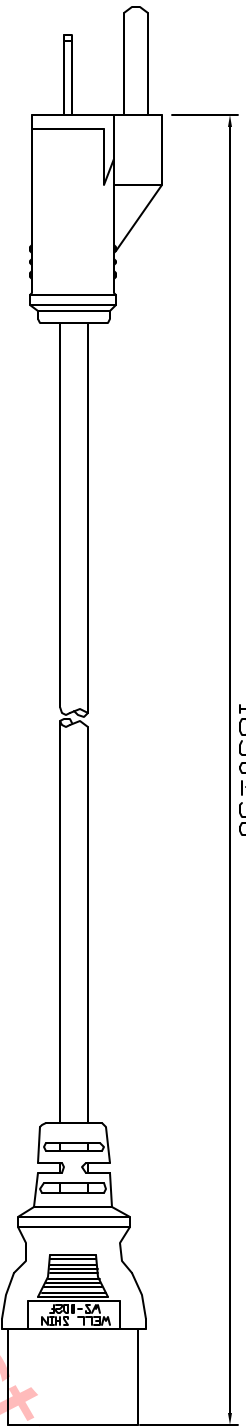

NEMA 5-20P

SPECIFICATION :

- (1) LENGTH : 1830 MM
- (2) COLOR : BLACK WIRE COLOR : (WHITE) (BLACK) (GREEN)
- (3) PLUG : WS-0011 (A) 20 (V) 125 APPROVAL : UL
- (4) CONNECTOR: WS-002F (A) 20 (V) 125 APPROVAL : UL,C-UL
- (5) CABLE : SJO 12AWG 3C 90°C APPROVAL : UL,C-UL

QUAIL ELECTRONICS

www.quail.com

CUSTOMER

DRAWING NO	096237	TITLE	0011+002F	DATE	12.06.99
REMARK		UNIT	MM	REV	B

REV.	DESCRIPTION	BY	APP.	DATE
A	SJD			11.18.99
B	90°C			12.06.99
C				

CHECK BY :

MANAGER

DRAWN BY

THE INFORMATION CONTAINED HEREIN IS PROPRIETARY TO QUAIL ELECTRONICS, INC. ANY USE OR DISCLOSURE OF THIS INFORMATION, EXCEPT FOR THE EXCLUSIVE BENEFIT OF QUAIL ELECTRONICS, INC. IS PROHIBITED.