



PEM® brand self-clinching nuts install permanently in aluminum, steel or stainless steel sheets.



CLTM



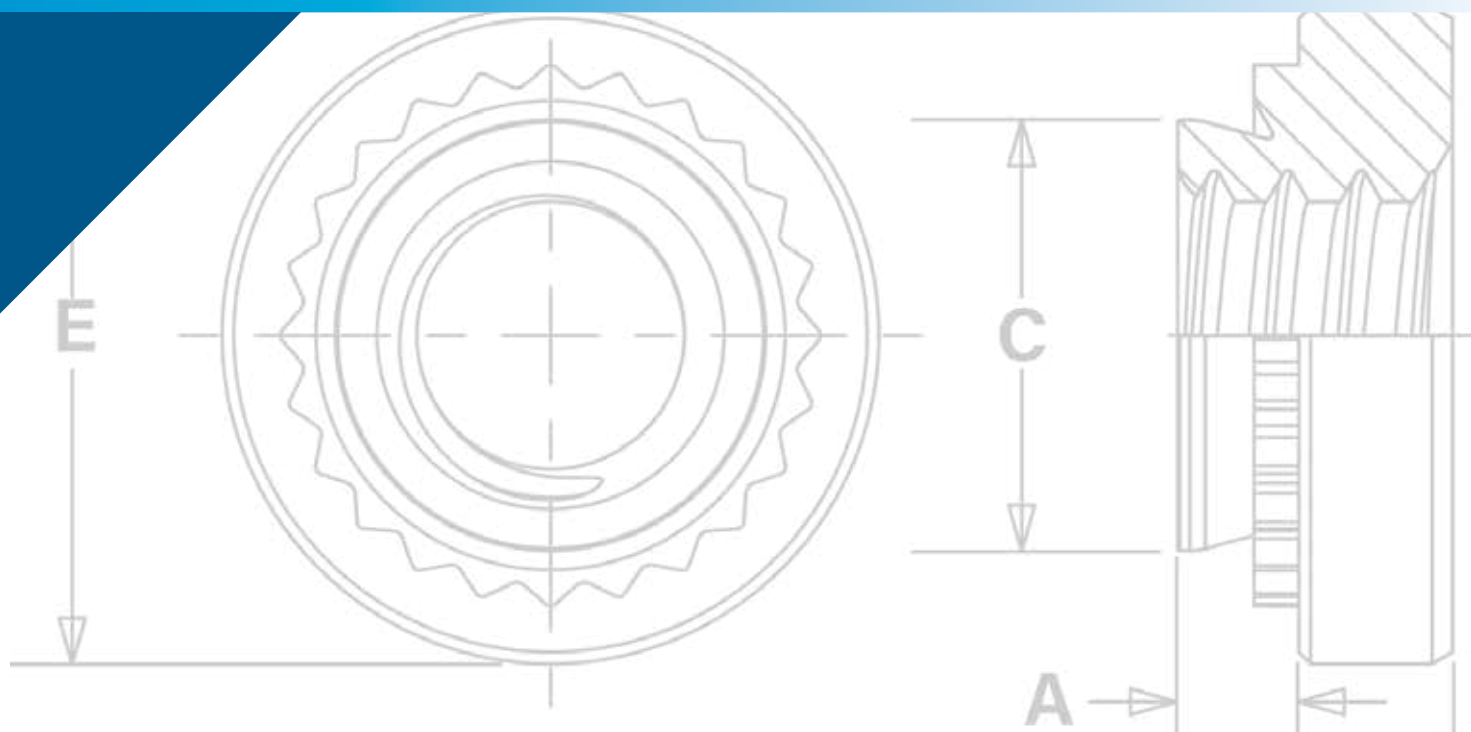



**SELF-CLINCHING
NUTS**

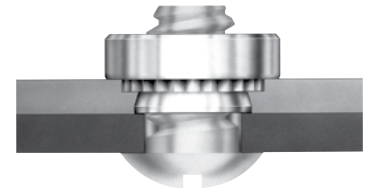

SELF-CLINCHING NUTS

Self-clinching nuts are installed by placing them in properly sized holes in sheets and applying a parallel squeezing force to the head of the nut. The sheet metal surrounding the head cold flows into an undercut thereby making the fastener an integral part of the sheet. A serrated clinching ring prevents the fastener from rotating after installation.



<p>S™/SS™/CLA™/CLS™/CLSS™ nuts provide load-bearing threads in thin sheets with high pushout and torque-out resistance - PAGES 4 and 5</p>		<p>H™ (non-locking) and HNL™ (locking) nuts have threads that provide high pushout and torque-out resistance - PAGE 8</p>	
<p>SP™, PEM 300® nuts provide strong load-bearing threads in stainless steel sheets as thin as .030"/0.8 mm - PAGES 4 and 5</p>		<p>SH™ hard panel nuts install into thin, harder, high strength steel materials - PAGE 8</p>	
<p>S-RT™ free-running locknuts are free-running until clamp load is induced. A modified thread angle on the loaded flank provides the vibration resistant locking feature- PAGE 6</p>	<p>NEW!</p> 	<p>SMPS™/SMPP™ nuts are for thinner sheet/close-to-edge applications - PAGE 9</p>	
<p>Material and finish specifications - PAGE 9</p>			
<p>Installation - PAGES 10 and 11</p>			
<p>Performance data - PAGES 12 - 15</p>			

Many PEM self-clinching nuts in this bulletin are dimensionally equivalent to nuts manufactured to NASM45938/1 specifications. Consult our Marketing department for a complete Military Specifications and National Aerospace Standards guide (Bulletin NASM) on our website.

Screws for use with PEM self-clinching locking fasteners should be Class 3A/4h fit or no smaller than Class 2A/6g.

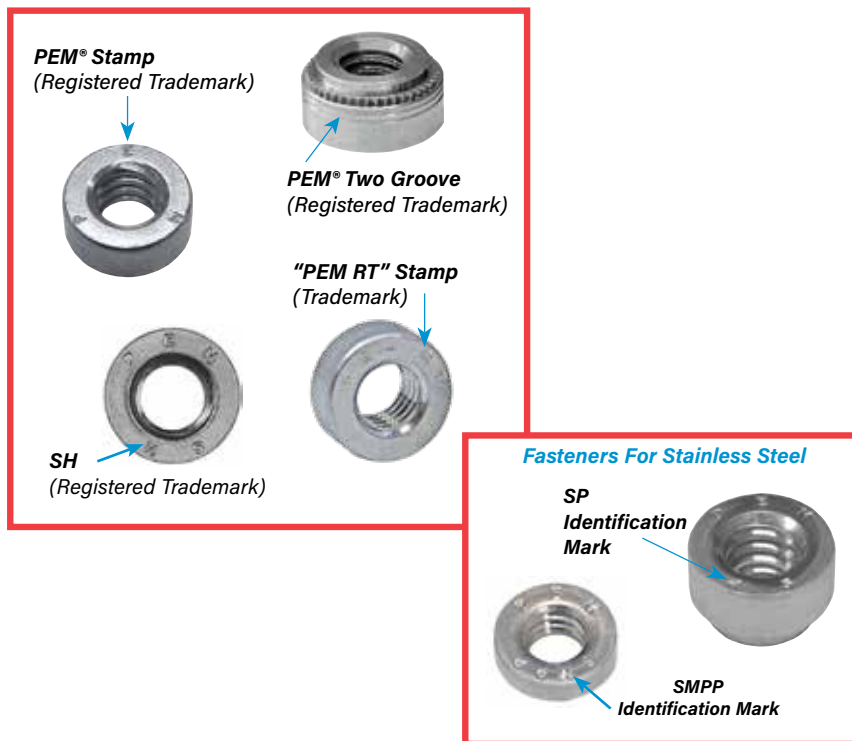

SELF-CLINCHING NUTS

PEM® SELF-CLINCHING NUT SELECTOR GUIDE

PEM Nut Type	Application Requires:									
	Recommended panel material (1)	Thinnest sheet .025" / 0.64 mm	Locking Threads		Closest centerline-to-edge distance	Superior corrosion resistance	Recommended for installation into stainless steel sheets	Compatible with aluminum anodizing	Harder high strength steel material	Non-magnetic
			Free-running	Prevailing torque						
S/SS/H	steel / aluminum									
CLS/CLSS	steel / aluminum					▪				▪
CLA	aluminum					▪	▪			▪
SP	stainless steel					▪	▪			▪
S-RT	steel / aluminum		▪							
SL	steel / aluminum			▪						
HNL	aluminum			▪						
SH	hardened alloy steel							▪		
SMPS	steel / aluminum	▪			▪	▪				▪
SMPP	stainless steel	▪			▪	▪	▪			▪

(1) Describes "best practice" for typical applications. Fasteners can be used in other panel materials not listed here if specified hardness limits are met. In all cases "For Use in Sheet Hardness" information is shown in chart on page 9.

Thread Mask

PEM® Blu-Coat™ thread mask is available for applications where hardware is installed prior to painting. During assembly, the threads of the mating hardware will remove paint, electro deposited automotive under coatings, and weld spatter upon application of torque. PEM nuts can be specially ordered with thread mask applied.



"BC" suffix will be added to part number to designate Blu-Coat thread mask to fastener.



Fastener drawings and models are available at www.pemnet.com

SELF-CLINCHING NUTS

- S/SS nuts are recommended for use in steel or aluminum sheets HRB 80 / HB 150 or less.
- CLS/CLSS nuts are recommended for use in steel or aluminum sheets HRB 70 / HB 125 or less.
- SP nuts are recommended for use in stainless steel sheets HRB 90 / HB 192 or less.
- CLA nuts are recommended for use in steel or aluminum sheets HRB 50 / HB 82 or less.

PART NUMBER DESIGNATION

S	-	632	-	1	ZI
SS	-	032	-	1	ZI
CL	S	-	632	-	1
CLS	S	-	032	-	1
S	P	-	632	-	1
CL	A	-	632	-	1

↓ Type
 ↓ Material Code
 ↓ Thread Size Code
 ↓ Shank Code
 ↓ Finish

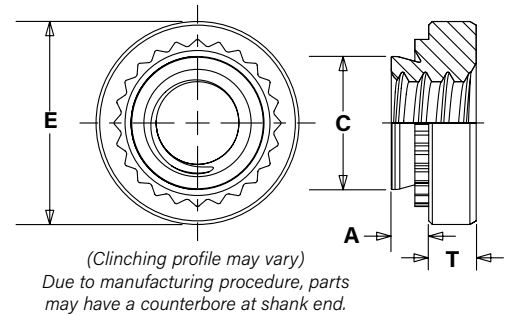

S™/SS™/CLS™/CLSS™/SP™ NUTS All dimensions are in inches.

Thread Size	Type			Thread Code	Shank Code	A (Shank) Max.	Rec. Min. Sheet Thickness (1)	Hole Size In Sheet +.003 -.000	C Max.	E ±.010	T ±.010	Min. Dist. Hole \varnothing To Edge
	Carbon Steel	Stainless Steel	Hardened Stainless Steel									
.086-56 (#2-56)	S	CLS	SP	256	0	.030	.030	.166	.165	.250	.070	.19
					1	.038	.040					
					2	.054	.056					
.099-48 (#3-48)	S	CLS	-	348	0	.030	.030	.166	.165	.250	.070	.19
					1	.038	.040					
					2	.054	.056					
.112-40 (#4-40)	S	CLS	SP	440	0	.030	.030	.166	.165	.250	.070	.19
					1	.038	.040					
					2	.054	.056					
					3 (2)	.087	.090					
.138-32 (#6-32)	S	CLS	SP	632	0	.030	.030	.1875	.187	.280	.070	.22
					1	.038	.040					
					2	.054	.056					
					3 (2)	.087	.090					
.164-32 (#8-32)	S	CLS	SP	832	0	.030	.030	.213	.212	.310	.090	.27
					1	.038	.040					
					2	.054	.056					
					3 (2)	.087	.090					
.190-24 (#10-24)	SS	CLSS	SP	024	0	.030	.030	.250	.249	.340	.090	.28
					1	.038	.040					
					2	.054	.056					
					3 (2)	.087	.090					
.190-32 (#10-32)	SS	CLSS	SP	032	0	.030	.030	.250	.249	.340	.090	.28
					1	.038	.040					
					2	.054	.056					
					3 (2)	.087	.090					
.216-24 (#12-24)	S	CLS	-	1224	1	.038	.040	.277	.276	.370	.130	.31
					2	.054	.056					
					3	.087	.090					
					0	.045	.047					
.250-20 (1/4-20)	S (3)	CLS	SP	0420	1	.054	.056	.344	.343	.440	.170	.34
					2	.087	.090					
					3 (2)	.120	.125					
					0	.054	.056					
.250-28 (1/4-28)	S	CLS	-	0428	1	.054	.056	.344	.343	.440	.170	.34
					2	.087	.090					
					3	.120	.125					
					0	.054	.056					
.313-18 (5/16-18)	S (3)	CLS	SP	0518	1	.054	.056	.413	.412	.500	.230	.38
					2	.087	.090					
					3 (2)	.120	.125					
					0	.054	.056					
.313-24 (5/16-24)	S	CLS	SP	0524	1	.054	.056	.413	.412	.500	.230	.38
					2	.087	.090					
					3 (2)	.120	.125					
					0	.087	.090					
.375-16 (3/8-16)	S	CLS	SP	0616	1	.087	.090	.500	.499	.560	.270	.44
					2	.120	.125					
					3 (2)	.235	.250					
					0	.087	.090					
.375-24 (3/8-24)	S	CLS	SP	0624	1	.087	.090	.500	.499	.560	.270	.44
					2	.120	.125					
					3 (2)	.235	.250					
					0	.087	.092					
.438-20 (7/16-20)	S	-	-	0720	1	.087	.092	.562	.561	.687	.311	.562
.500-13 (1/2-13)	S	CLS	-	0813	1	.120	.125	.656	.655	.810	.360	.63
					2	.235	.250					
.500-20 (1/2-20)	S	CLS	-	0820	1	.120	.125	.656	.655	.810	.360	.63
					2	.235	.250					

- For maximum performance, we recommend that you use the maximum shank length for your sheet thickness.
- This shank code not available for SP nuts.
- This thread size S nut, with a -2 shank code, can be installed successfully without the need to pre punch a mounting hole in a separate operation. See page 15 for more information.

The increased hardness of stainless steel panels requires careful consideration when installing self-clinching fasteners. See page 16 or refer to Fastener Installation Dos and Don'ts on our web site.



SELF-CLINCHING NUTS

S™/SS™/CLS™/CLSS™/SP™ NUTS

(See drawing at top of page 4) All dimensions are in millimeters.

METRIC	Thread Size	Type			Thread Code	Shank Code	A (Shank) Max.	Rec. Min. Sheet Thickness (t)	Hole Size In Sheet +0.08	C Max.	E ±0.25	T ±0.25	Min. Dist. Hole To Edge
		Fastener Material											
		Carbon Steel	Stainless Steel	Hardened Stainless Steel									
M2 x 0.4	S	CLS	SP	M2	0 ⁽²⁾	0.77	0.8	4.22	4.2	6.35	1.5	4.8	
					1	0.97	1						
					2	1.38	1.4						
M2.5 x 0.45	S	CLS	SP	M2.5	0	0.77	0.8	4.22	4.2	6.35	1.5	4.8	
					1	0.97	1						
					2	1.38	1.4						
M3 x 0.5	S	CLS	SP	M3	0	0.77	0.8	4.22	4.2	6.35	1.5	4.8	
					1	0.97	1						
					2	1.38	1.4						
M3.5 x 0.6	S	CLS	—	M3.5	0	0.77	0.8	4.75	4.73	7.11	1.5	5.6	
					1	0.97	1						
					2	1.38	1.4						
M4 x 0.7	S	CLS	SP	M4	0	0.77	0.8	5.41	5.38	7.87	2	6.9	
					1	0.97	1						
					2	1.38	1.4						
M5 x 0.8	SS	CLSS	SP	M5	0	0.77	0.8	6.35	6.33	8.64	2	7.1	
					1	0.97	1						
					2	1.38	1.4						
M6 x 1	S ⁽³⁾	CLS	SP	M6	00 ⁽²⁾	0.89	0.92	8.75	8.73	11.18	4.08	8.6	
					0 ⁽²⁾	1.15	1.2						
					1	1.38	1.4						
					2	2.21	2.29						
M8 x 1.25	S ⁽³⁾	CLS	SP	M8	1	1.38	1.4	10.5	10.47	12.7	5.47	9.7	
					2	2.21	2.29						
M10 x 1.5	S	CLS	SP	M10	1	2.21	2.29	14	13.97	17.35	7.48	13.5	
					2 ⁽²⁾	3.05	3.18						
M12 x 1.75	S	—	—	M12	1	3.05	3.18	17	16.95	20.57	8.5	16	

CLA™ NUTS

(See drawing at top of page 4) All dimensions are in inches.

UNIFIED	Thread Size	Type	Thread Code	Shank Code	A (Shank) Max.	Min. Sheet Thickness (t)	Hole Size In Sheet ±.003-.000	C Max.	E ±.010	T ±.010	Min. Dist. Hole To Edge
		Fastener Material									
		Aluminum									
.086-56 (#2-56)	CLA	256	1	.038	.040	.166	.165	.250	.070	.19	
			2	.054	.056						
.112-40 (#4-40)	CLA	440	1	.038	.040	.1875	.187	.250	.090	.22	
			2	.054	.056						
.138-32 (#6-32)	CLA	632	1	.038	.040	.213	.212	.280	.090	.27	
			2	.054	.056						
.164-32 (#8-32)	CLA	832	1	.038	.040	.234	.233	.310	.130	.28	
			2	.054	.056						
.190-24 (#10-24)	CLA	024	1	.038	.040	.296	.295	.370	.160	.31	
			2	.054	.056						
.190-32 (#10-32)	CLA	032	1	.038	.040	.296	.295	.370	.160	.31	
			2	.054	.056						
.250-20 (1/4-20)	CLA	0420	1	.054	.056	.344	.343	.440	.170	.34	
			2	.087	.091						
			3	.120	.125						

(See drawing at top of page 4) All dimensions are in millimeters.

METRIC	Thread Size x Pitch	Type	Thread Code	Shank Code	A (Shank) Max.	Min. Sheet Thickness (t)	Hole Size In Sheet +0.08	C Max.	E ±0.25	T ±0.25	Min. Dist. Hole To Edge
		Fastener Material									
		Aluminum									
M2 x 0.4	CLA	M2	1	0.98	1	4.22	4.2	6.35	1.5	4.8	
			2	1.38	1.4						
M3 x 0.5	CLA	M3	1	0.98	1	4.75	4.73	6.35	2	5.6	
			2	1.38	1.4						
M3.5 x 0.6	CLA	M3.5	1	0.98	1	5.41	5.38	7.11	2	6.9	
			2	1.38	1.4						
M4 x 0.7	CLA	M4	1	0.98	1	5.94	5.92	7.8	3	7.1	
			2	1.38	1.4						
M5 x 0.8	CLA	M5	1	0.98	1	7.52	7.49	9.4	3.8	7.9	
			2	1.38	1.4						
M6 x 1	CLA	M6	1	1.38	1.4	8.75	8.73	11.18	4.08	8.6	
			2	2.21	2.3						

(1) For maximum performance, we recommend that you use the maximum shank length for your sheet thickness.

(2) This shank code not available for SP nuts.

(3) This thread size S nut, with a -2 shank code, can be installed successfully without the need to pre punch a mounting hole in a separate operation. See page 15 for more information.





S-RT™ FREE-RUNNING LOCKNUTS

Free-running locking feature allows screw to turn freely until clamp load is applied. If the tightening force is removed, these nuts no longer provide any torsional resistance to rotation.

- Resistant to vibrational loosening.
- Back side of panel is flush or sub-flush for screw installation.
- Locking feature reusability is not affected by number of on/off cycles.
- Uses same mounting hole and installation tooling as standard S™ nuts.
- Recommended for use in steel or aluminum sheets HRB 80 / HB 150 or less.

PART NUMBER DESIGNATION

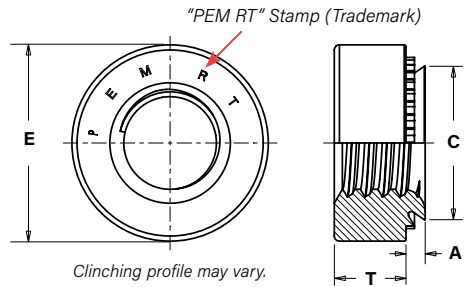
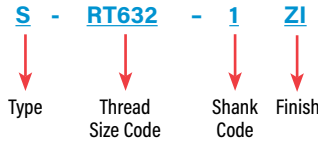

All dimensions are in inches.

UNIFIED	Thread Size	Type	Thread Code	Shank Code	A (Shank) Max.	Rec. Min. Sheet Thickness (t)	Hole Size In Sheet +.003 -.000	C Max.	E ±.010	T ±.010	Min. Dist Hole \varnothing To Edge
	.112-40 (#4-40)	S	RT440	0	.030	.030	.166	.165	.250	.070	.19
1				.038	.040						
2				.054	.056						
.138-32 (#6-32)	S	RT632	0	.030	.030	.1875	.187	.280	.070	.22	
			1	.038	.040						
			2	.054	.056						
.164-32 (#8-32)	S	RT832	0	.030	.030	.213	.212	.310	.090	.27	
			1	.038	.040						
			2	.054	.056						
.190-32 (#10-32)	SS	RT032	0	.030	.030	.250	.249	.340	.090	.28	
			1	.038	.040						
			2	.054	.056						
.250-20 (1/4-20)	S	RT0420	0	.045	.047	.344	.343	.440	.170	.34	
			1	.054	.056						
			2	.087	.090						
.313-18 (5/16-18)	S	RT0518	0	.054	.056	.413	.412	.500	.230	.38	
			1	.054	.056						
			2	.087	.090						

All dimensions are in millimeters

METRIC	Thread Size x Pitch	Type	Thread Code	Shank Code	A (Shank) Max.	Rec. Min. Sheet Thickness (t)	Hole Size In Sheet +0.08	C Max.	E ±0.25	T ±0.25	Min. Dist Hole \varnothing To Edge
	M3 x 0.5	S	RTM3	0	0.77	0.8	4.22	4.2	6.35	1.5	4.8
1				0.97	1						
2				1.38	1.4						
M4 x 0.7	S	RTM4	0	0.77	0.8	5.41	5.38	7.87	2	6.9	
			1	0.97	1						
			2	1.38	1.4						
M5 x 0.8	SS	RTM5	0	0.77	0.8	6.35	6.33	8.64	2	7.1	
			1	0.97	1						
			2	1.38	1.4						
M6 x 1	S	RTM6	00	0.89	0.92	8.75	8.73	11.18	4.08	8.6	
			0	1.15	1.2						
			1	1.38	1.4						
			2	2.21	2.29						

The graph represents the clamp load of the joint versus the amount of cycles during transverse vibration testing for an S-RT™ free-running locknut, a standard hex nut and a hex nut with a split ring lock washer.

Testing conditions:

- Transverse vibration testing.
- M6 thread size nuts, average of 30 pieces.
- Clamp load applied using metric property class 10.9 screws.
- Nuts tested until loss of clamp load or 2,000 cycles is reached.

Details on PEM® RT™ vibration resistant thread technology can be found on our web site at: https://www.pemnet.com/files/design_info/techsheets/RT_Thread_Form.pdf

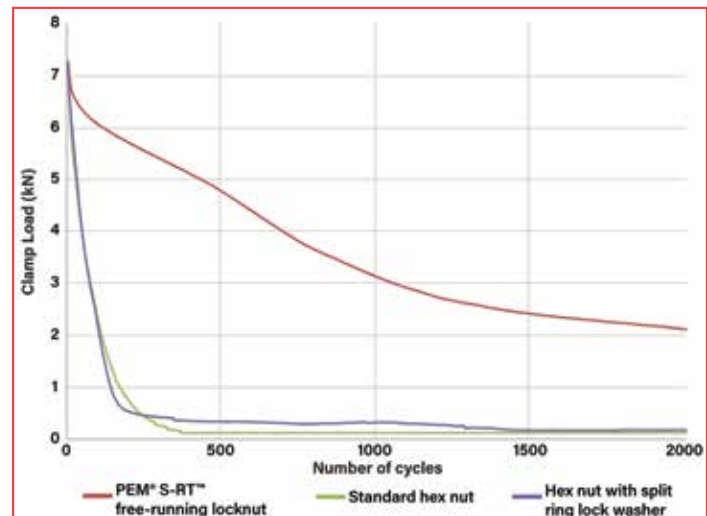

SELF-CLINCHING NUTS

SL™ TRI-DENT® PREVAILING TORQUE LOCKNUTS

Prevailing torque locking feature produces friction between threads of mated components thereby increasing the force needed to tighten as well as loosen the nut. Prevailing torque locknuts provide essentially the same torque value regardless of the amount axial load applied.

- 3 cycle locking performance. ⁽¹⁾
- Resistant to vibrational loosening.
- Back side of panel is flush or sub-flush for screw installation.
- Uses same mounting hole and installation tooling as standard S™ nuts.
- Recommended for use in sheets HRB 80 / HB 150 or less.

PART NUMBER DESIGNATION

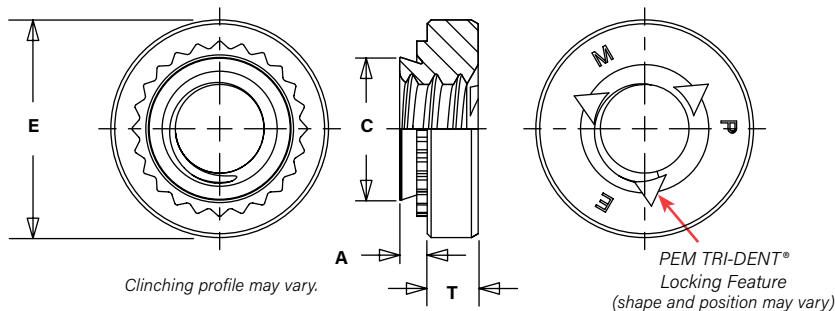
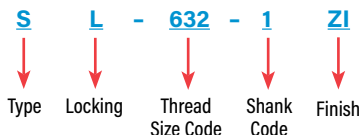

All dimensions are in inches.

UNIFIED	Thread Size	Type	Thread Code	Shank Code	A (Shank) Max.	Min. Sheet Thickness	Hole Size In Sheet +.003 -.000	C Max.	E ±.010	T ±.010	Min. Dist. Hole To Edge
	.112-.40 (#4-40)	SL	440	1	.038	.040	.166	.165	.250	.070	.19
				2	.054	.056					
	.138-.32 (#6-32)	SL	632	1	.038	.040	.1875	.187	.280	.070	.22
				2	.054	.056					
	.164-.32 (#8-32)	SL	832	1	.038	.040	.213	.212	.310	.090	.27
				2	.054	.056					
	.190-.32 (#10-32)	SL	032	1	.038	.040	.250	.249	.340	.090	.28
				2	.054	.056					
	.250-.20 (1/4-20)	SL	0420	1	.054	.056	.344	.343	.440	.170	.34
2				.087	.091						
.313-.18 (5/16-18)	SL	0518	1	.054	.056	.413	.412	.500	.230	.38	
			2	.087	.091						
.375-.16 (3/8-16)	SL	0616	1	.087	.090	.500	.499	.625	.270	.44	
			2	.120	.125						

All dimensions are in millimeters.

METRIC	Thread Size x Pitch	Type	Thread Code	Shank Code	A (Shank) Max.	Min. Sheet Thickness	Hole Size In Sheet +0.08	C Max.	E ±0.25	T ±0.25	Min. Dist. Hole To Edge
	M3 x 0.5	SL	M3	1	0.98	1	4.22	4.2	6.35	1.5	4.8
				2	1.38	1.4					
	M3.5 x 0.6	SL	M3.5	1	0.98	1	4.75	4.73	7.11	1.5	5.6
				2	1.38	1.4					
	M4 x 0.7	SL	M4	1	0.98	1	5.41	5.38	7.87	2	6.9
				2	1.38	1.4					
	M5 x 0.8	SL	M5	1	0.98	1	6.35	6.33	8.64	2	7.1
				2	1.38	1.4					
	M6 x 1	SL	M6	1	1.38	1.4	8.75	8.73	11.18	4.08	8.6
2				2.21	2.3						
M8 x 1.25	SL	M8	1	1.38	1.4	10.5	10.47	12.7	5.47	9.7	
			2	2.21	2.3						
M10 x 1.5	SL	M10	1	2.21	2.29	14	13.97	17.35	7.48	13.5	
			2	3.05	3.18						

(1) Achieved using steel socket head cap screws, 180 ksi / property class 12.9 with standard finish of thermal oxide and light oil.



SELF-CLINCHING NUTS

H™ NUTS AND HNL™ PREVAILING TORQUE LOCKNUTS

- Meets torque requirements for IFI 100/107 Grade B (unified) and ANSI B18.16.1M (metric) locknuts.
- H nut is recommended for use in sheets HRB 80 / HB 150 or less.
- HNL nut is recommended for use in sheets HRB 60 / HB 107 or less.

PART NUMBER DESIGNATION

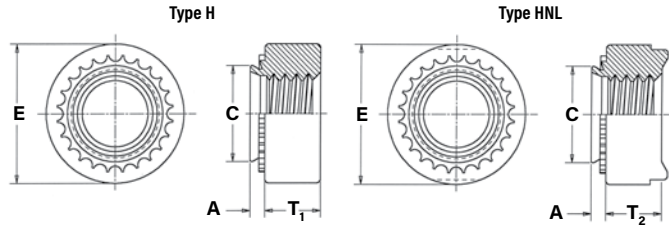
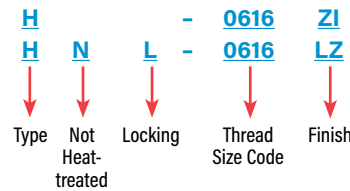

Clinching profile may vary.

All dimensions are in inches.

UNIFIED	Thread Size	Type		Thread Code	A (Shank) Max.	Min. Sheet Thickness	Hole Size In Sheet +.005 -0.000	C Max.	E ±.010	T ₁	T ₂	Min. Dist. Hole To Edge
		Non-Locking	Self-Locking (1)							Non-locking	Self-locking	
										±.005	±.010	
.250-20 (1/4-20)	—	HNL	0420	.058	.058	.344	.343	.500	.189		.380	
.313-18 (5/16-18)	—	HNL	0518	.058	.058	.413	.412	.575	.240		.420	
.375-16 (3/8-16)	H	HNL	0616	.058	.058	.500	.499	.650	.300		.480	

All dimensions are in millimeters.

METRIC	Thread Size x Pitch	Type		Thread Code	A (Shank) Max.	Min. Sheet Thickness	Hole Size In Sheet +0.13	C Max.	E ±0.25	T ₁	T ₂	Min. Dist. Hole To Edge
		Non-Locking	Self-Locking (1)							Non-locking	Self-locking	
										±0.13	±0.25	
M6 x 1	—	HNL	M6	1.48	1.48	8.75	8.72	12.7	5		10	
M8 x 1.25	—	HNL	M8	1.48	1.48	10.5	10.47	14.6	6.3		11	
M10 x 1.5	H	HNL	M10	1.48	1.48	12.7	12.67	16.5	7.9		12	

(1) During installation, the projections on the heads of HNL self-locking nuts may be flattened. This is not detrimental in any way and will not affect self-locking or self-clinching performance.

SH™ HARD PANEL NUTS

- Installs into harder, high strength steel materials (high strength steel sheets up to 975MPa tensile strength).
- Hardened nut material provides stronger thread strength.

PART NUMBER DESIGNATION

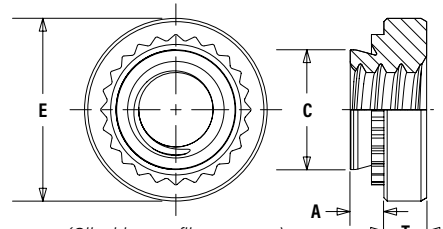
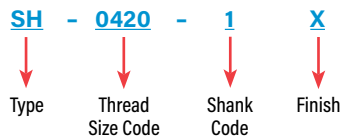

(Clinching profile may vary)
Due to manufacturing procedure, parts may have a counterbore at shank end.

All dimensions are in inches.

UNIFIED	Thread Size	Type		Thread Code	Shank Code	A (Shank) Max.	Min. Sheet Thickness (1)	Hole Size in Sheet +.003 -.000	C Max.	E ±.010	T ±.010	Min. Dist. Hole To Edge
		Fastener Material	Hardened Alloy Steel									
.313-18 (5/16-18)	SH	0518	1	.054	.056	.413	.412	.500	.230	.38		
			2	.087	.090							
.375-16 (3/8-16)	SH	0616	1	.087	.090	.500	.499	.623	.270	.44		

All dimensions are in millimeters.

METRIC	Thread Size x Pitch	Type		Thread Code	Shank Code	A (Shank) Max.	Min. Sheet Thickness (1)	Hole Size in Sheet +0.08	C Max.	E ±0.25	T ±0.25	Min. Dist. Hole To Edge
		Fastener Material	Hardened Alloy Steel									
2	2.21	2.29										
M8 x 1.25	SH	M8	1	1.38	1.4	10.5	10.47	12.7	5.47	9.7		
			2	2.21	2.29							
M10 x 1.5	SH	M10	1	2.21	2.29	14	13.97	17.35	7.48	13.5		

(1) For maximum performance, we recommend that you use the maximum shank length for your sheet thickness.



SELF-CLINCHING NUTS

SMPS™/SMPP™ NUTS

- Installs into sheets as thin as .025" / 0.64 mm.
- Reduced outer dimensions and thinner sheet capabilities compared to Type S/SP thread sizes.
- SMPS nut is recommended for use in sheets HRB 70 / HB 125 or less.
- SMPP nut is recommended for use in stainless steel sheets HRB 90 / HB 192 or less.

PART NUMBER DESIGNATION

SMPS - 440
SMPP - 440

Type Thread Size Code

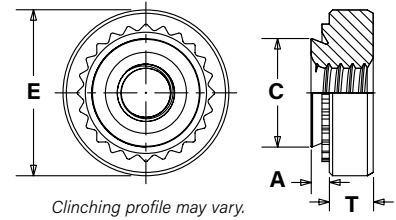

All dimensions are in inches.

UNIFIED	Thread Size	Type		Thread Code	A (Shank) Max.	Min. Sheet Thickness	Hole Size In Sheet +.003 -.000	C Max.	E ±.010	T ±.010	Min. Dist. Hole To Edge	
		Fastener Material									SMPS	SMPP
		Stainless Steel	Hardened Stainless Steel									
	.086-56 (#2-56)	SMPS	SMPP	256	.024	.025	.136	.135	.220	.065	.15	.16
	.112-40 (#4-40)	SMPS	SMPP	440	.024	.025	.166	.165	.220	.065	.17	.20
	.138-32 (#6-32)	SMPS	SMPP	632	.024	.025	.187	.186	.252	.065	.20	.22

All dimensions are in millimeters.

METRIC	Thread Size x Pitch	Type		Thread Code	A (Shank) Max.	Min. Sheet Thickness	Hole Size In Sheet +0.08	C Max.	E ±0.25	T ±0.25	Min. Dist. Hole To Edge	
		Fastener Material									SMPS	SMPP
		Stainless Steel	Hardened Stainless Steel									
	M2.5 x 0.45	SMPS	SMPP	M2.5	0.61	0.64	3.8	3.79	5.6	1.4	3.7	3.9
	M3 x 0.5	SMPS	SMPP	M3	0.61	0.64	4.24	4.22	5.6	1.4	4.3	5.1
	M3.5 x 0.6	SMPS	SMPP	M3.5	0.61	0.64	4.75	4.73	6.4	1.4	5.1	5.5

MATERIAL AND FINISH SPECIFICATIONS

Type	Threads			Fastener Materials						Standard Finishes				Optional Finish	For use in Sheet Hardness (8)					
	Internal ASME B1.1 ZB/ASME B1.13M, 6H	Meets Torque Requirements for IFI 100/107 Grade B (unified) and ANSI B18.16.1M (metric) Locknuts	3 Cycle Locking Performance	Hardened Carbon Steel	300 Series Stainless Steel	Aluminum	Carbon Steel	Hardened Alloy Steel	Age Hardened A286 Stainless Steel	Passivated and/or Tested per ASTM A380	Zinc Plated, 5µm, Colorless (4)	Zinc Plated, 5µm, Colorless Plus Sealant/Lubricant (4)	No Finish (3)	Zinc Plated, 5µm, Yellow (4)	HRC 30/ HB 277 or less	HRB 90/ HB 192 or less	HRB 80/ HB 150 or less	HRB 70/ HB 125 or less	HRB 60/ HB 107 or less	HRB 50/ HB 82 or less
S	▪			▪							▪			▪						
SS	▪			▪							▪			▪						
CLS	▪				▪					▪								▪		
CLSS	▪				▪					▪								▪		
CLA	▪					▪							▪ (2)							▪
H	▪			▪							▪			▪						
SP	▪								▪							▪				
S-RT	▪									▪										
SL	▪		▪	▪							▪									
HNL	▪	▪										▪								▪
SH	▪												▪ (5)							
SMPS	▪									▪										▪
SMPP	▪									▪										▪
Part number codes for finishes										None	ZI	LZ	X	ZC						

- Special order with additional charge.
- Part numbers for aluminum nuts have no plating suffix.
- Unplated threads are sized to accept a basic go gauge after .00025" / 0.0064 mm plating.
- See PEM Technical Support section of our web site for related plating standards and specifications.

- With rust preventative oil.
- Panel material should be in the annealed condition.
- Fasteners should not be installed adjacent to bends or other highly cold-worked areas.
- HRB - Hardness Rockwell "B" Scale. HRC - Hardness Rockwell "C" Scale. HB - Hardness Brinell.



SELF-CLINCHING NUTS

INSTALLATION - S™/SL™/SMPS™/SS™/CLS™/CLSS™/CLA™/S-RT™/H™/HNL™ NUTS

1. Prepare properly sized mounting hole in sheet. Do not perform any secondary operations such as deburring.
2. Place fastener into the anvil hole and place the mounting hole (preferably the punch side) over the shank of the fastener as shown in diagram to the right.
3. With installation punch and anvil surfaces parallel, apply squeezing force until the head of the nut comes into contact with the sheet material.

COUNTERBORE ANVIL
Thread Sizes #2-56 to 5/16
and M2 to M8

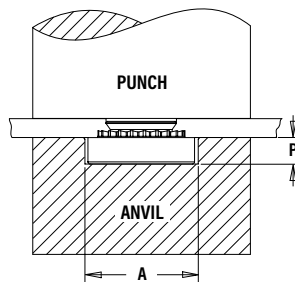

PROTRUSION ANVIL (1)

CLS/S/SL/S-RT Thread Sizes 3/8, 7/16, 1/2, M10 and M12
H/HNL Thread Sizes 5/16, 3/8, M8 and M10

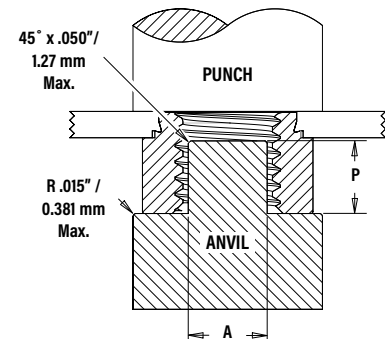

PEMSERTER® Installation Tooling

CLS™/CLSS™/S™/SS™/S-RT™ NUTS

UNIFIED	Thread Code	Anvil Dimensions (in.)		Anvil Part Number	Punch Part Number
		A ±.002	P ±.005		
	256/440/RT440	.267	.045	975200034	975200048
	632/RT632	.298	.045	975200035	975200048
	832/RT832	.330	.070	975200036	975200048
	024/032/RT032	.361	.070	975200037	975200048
	1224	.415	.080	975200786300	975200048
	0420/RT0420	.454	.150	975200038	975200048
	0518/RT0518	.517	.200	975200039	975200048
	0616	.280	.250	975200045 (1)	975200048
	0720	.338	.295	8020361 (1)	975200901400
	0813	.375	.345	975200900300 (1)	975200901400

METRIC	Thread Code	Anvil Dimensions (mm)		Anvil Part Number	Punch Part Number
		A ±0.05	P ±0.13		
	M2/M3/RTM3	6.78	1.14	975200034	975200048
	M3.5	7.57	1.14	975200035	975200048
	M4/RTM4	8.38	1.78	975200036	975200048
	M5/RTM5	9.17	1.78	975200037	975200048
	M6/RTM6	11.53	3.81	975200038	975200048
	M8	13.08	5.08	975200039	975200048
	M10	7.62	6.35	8005682 (1)	975200901400
	M12	9.53	8.76	975200900300 (1)	975200901400

CLA™ NUTS

UNIFIED	Thread Code	Anvil Dimensions (in.)		Anvil Part Number	Punch Part Number
		A ±.002	P ±.005		
	256/440	.267	.045	975200034	975200048
	632	.298	.045	975200035	975200048
	832	.330	.070	975200036	975200048
	024/032	.392	.140	975200782300	975200048
	0420	.454	.150	975200038	975200048

METRIC	Thread Code	Anvil Dimensions (mm)		Anvil Part Number	Punch Part Number
		A ±0.05	P ±0.13		
	M3	6.78	1.14	975200034	975200048
	M3.5	7.57	1.14	975200035	975200048
	M4	8.38	1.78	975200036	975200048
	M5	9.96	3.56	975200782300	975200048
	M6	11.53	3.81	975200038	975200048

(1) Large nut anvils use protrusion to locate part instead of counterbore.

SL™ NUTS

UNIFIED	Thread Code	Anvil Dimensions (in.)		Anvil Part Number	Punch Part Number
		A ±.002	P ±.005		
	440	.267	.045	975200034	975200048
	632	.298	.045	975200035	975200048
	832	.330	.070	975200036	975200048
	032	.361	.070	975200037	975200048
	0420	.454	.150	975200038	975200048
	0518	.515	.200	975200039	975200048
	0616	.280	.250	975200045 (1)	975200048

METRIC	Thread Code	Anvil Dimensions (mm)		Anvil Part Number	Punch Part Number
		A ±0.05	P ±0.13		
	M3	6.78	1.14	975200034	975200048
	M3.5	7.57	1.14	975200035	975200048
	M4	8.38	1.78	975200036	975200048
	M5	9.17	1.78	975200037	975200048
	M6	11.53	3.81	975200038	975200048
	M8	13.08	5.08	975200039	975200048
	M10	7.62	6.35	8005682 (1)	975200901400

SMPS™ NUTS

UNIFIED	Thread Code	Anvil Dimensions (in.)		Anvil Part Number	Punch Part Number
		A ±.002	P ±.005		
	256/440	.236	.045	975200904300	975200048
	632	.267	.045	975200034	975200048

METRIC	Thread Code	Anvil Dimensions (mm)		Anvil Part Number	Punch Part Number
		A ±0.05	P ±0.13		
	M2.5/M3	5.99	1.14	975200904300	975200048
	M3.5	6.78	1.14	975200034	975200048

H™/HNL™ NUTS

UNIFIED	Thread Code	Anvil Dimensions (in.)		Anvil Part Number	Punch Part Number
		A ±.002	P ±.005		
	0420	.517	.200	975200039	975200048
	0518	.220	.250	975200783300 (1)	975200048
	0616	.280	.250	975201240 (1)	8003076

METRIC	Thread Code	Anvil Dimensions (mm)		Anvil Part Number	Punch Part Number
		A ±0.05	P ±0.13		
	M6	13.13	5.08	975200039	975200048
	M8	5.59	6.35	975200783300 (1)	975200048
	M10	7.62	6.35	8005682 (1)	8003076



SELF-CLINCHING NUTS

INSTALLATION - SP™/SMPP™ NUTS (1)

1. Prepare properly sized mounting hole in sheet. Do not perform any secondary operations such as deburring.
2. Place fastener into the recommended counterbore anvil hole and place the mounting hole (preferably the punch side) over the shank of the fastener as shown in diagram.
3. With installation punch and anvil surfaces parallel, apply squeezing force until the head of the nut comes into contact with the sheet material.

PEMSERTER® Installation Tooling

SP™ NUTS

UNIFIED	Thread Code	Anvil Dimensions (in.)				Anvil Part Number	Punch Part Number
		A	P +.000	R	R _i		
		±.002	-.001	Max.	+.005		
440	.255	.064	.010	.005	8012821	975200048	
632	.286	.064	.010	.005	8012822		
832	.317	.082	.010	.005	8012823		
024/032	.348	.082	.010	.005	8012824		
0420	.443	.163	.010	.005	8012825	8003076	
0518	.505	.230	.010	.005	8015359		
0616/0624	.570	.263	.010	.005	8015863		

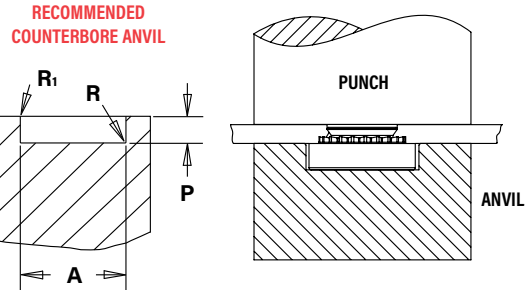

SMPP™ NUTS

UNIFIED	Thread Code	Anvil Dimensions (in.)				Anvil Part Number	Punch Part Number
		A	P +.000	R	R _i		
		±.002	-.001	Max.	+.005		
256	.223	.060	.010	.005	8020023	975200048	
440	.233	.060	.010	.005	8021386		
632	.255	.060	.010	.005	8020024		

METRIC	Thread Code	Anvil Dimensions (mm)				Anvil Part Number	Punch Part Number
		A	P	R	R _i		
		±0.05	-0.03	Max.	+0.13		
M2.5	5.66	1.27	0.25	0.13	8020025	975200048	
M3	5.9	1.27	0.25	0.13	8021474		
M3.5	6.48	1.27	0.25	0.13	8020026		

METRIC	Thread Code	Anvil Dimensions (mm)				Anvil Part Number	Punch Part Number
		A	P	R	R _i		
		±0.05	-0.03	Max.	+0.13		
M2	6.48	1.63	0.25	0.13	8012821	975200048	
M2.5-0	6.48	1.42	0.25	0.13	8019477		
M2.5-1,-2	6.48	1.63	0.25	0.13	8012821		
M3	6.48	1.63	0.25	0.13	8012821		
M3.5	7.26	1.63	0.25	0.13	8012822		
M4	8.05	2.08	0.25	0.13	8012823		
M5	8.84	2.08	0.25	0.13	8012824	8003076	
M6	11.25	4.14	0.25	0.13	8012825		
M8	12.83	5.41	0.25	0.13	8015360		
M10	17.58	7.47	0.25	0.13	8015886		

(1) For best results, we recommend using the installation punch and anvil shown. Deviations from recommended installation tooling may result in sheet distortion and reduced performance.

NOTE: Variations in hole preparation, installation tooling, installation force, and sheet material type, thickness, and hardness will affect both performance and tooling life.

INSTALLATION - SH™ NUTS

1. Prepare properly sized mounting hole in sheet. Do not perform any secondary operations such as deburring.
2. Place fastener into the anvil hole and place the mounting hole (preferably the punch side) over the shank of the fastener as shown in diagram to the right.
3. With installation punch and anvil surfaces parallel, apply squeezing force until the head of the nut comes into contact with the sheet material.

PEMSERTER® Installation Tooling

UNIFIED	Thread Code	Anvil Dimensions (in.)		Anvil Part Number	Punch Part Number
		A	P		
		±.002	±.005		
0420	.454	.150	975200038	975200048	
0518	.517	.200	975200039	975200048	
0616	.280	.250	8020084 ⁽¹⁾	9752000901400	

METRIC	Thread Code	Anvil Dimensions (mm)		Anvil Part Number	Punch Part Number
		A	P		
		±0.05	±0.13		
M6	11.53	3.81	975200038	975200048	
M8	13.13	5.08	975200039	975200048	
M10	16.27	6.35	8005682 ⁽¹⁾	9752000901400	

(1) Large nut anvils use protrusion to locate part instead of counterbore.

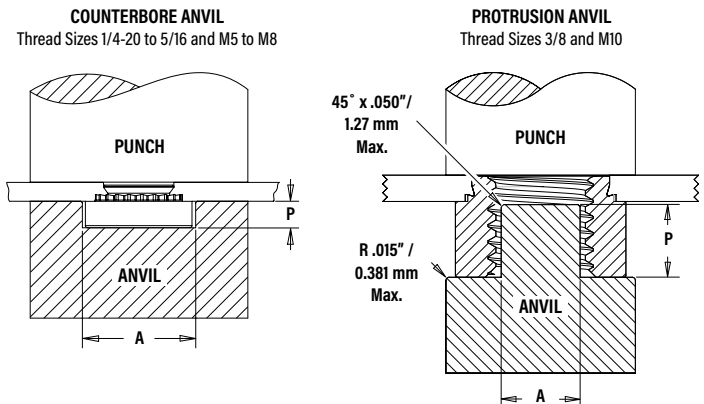

INSTALLATION NOTES

- For best results we recommend using a PEMSERTER® press for installation of PEM self-clinching fasteners. Please check our website for more information.
- Visit the Animation Library on our website to view the installation process for [select products](#).



SELF-CLINCHING NUTS

PERFORMANCE DATA⁽¹⁾

S™/CLS™/CLSS™ NUTS

Type	Thread Code	Shank Code	Test Sheet Material	Installation (lbs.)	Pushout (lbs.)	Torque-out (in. lbs.)
S CLS	256 348 440	0	5052-H34 Aluminum	1500-2000	63	8
		1			90	10
		2			170	13
		3	170		13	
		0	Cold-rolled Steel		105	13
		1			125	15
2	230	18				
3	230	18				
S CLS	632	0	5052-H34 Aluminum	2500-3000	63	16
		1			95	17
		2			190	22
		3	190		22	
		0	Cold-rolled Steel		110	16
		1			130	20
2	275	28				
3	275	28				
S CLS	832	0	5052-H34 Aluminum	2500-3000	68	21
		1			105	23
		2			220	35
		3	220		35	
		0	Cold-rolled Steel		110	26
		1			145	35
2	285	45				
3	285	45				
SS CLSS	024 032	0	5052-H34 Aluminum	2500-3500	68	26
		1			110	32
		2			190	50
		3	225		50	
		0	Cold-rolled Steel		120	32
		1			180	40
2	320	60				
3	320	60				
S CLS	1224	1	5052-H34 Aluminum	2500-6500	120	63
		2			285	70
		3			285	70
		1	Cold-rolled Steel		200	74
		2			350	80
		3			350	80
S CLS	0420	0	5052-H34 Aluminum	4000-7000	220	70
		1			360	125
		2			315	115
		3	315		115	
		0	Cold-rolled Steel		400	150
		1			400	150
2	400	150				
3	400	150				
S CLS	0518 0524	1	5052-H34 Aluminum	4000-7000	380	120
		2			380	160
		3			380	160
		1	Cold-rolled Steel		420	165
		2			420	180
		3			420	180
S CLS	0616 0624	1	5052-H34 Aluminum	5000-8000	400	270
		2			400	270
		3			400	270
		1	Cold-rolled Steel		460	320
		2			460	320
		3			460	320
S	0720	1	Cold-rolled Steel	9000-13000	450	340
S CLS	0813 0820	1	5052-H34 Aluminum	7000-9000	475	350
		2	5052-H34 Aluminum	7000-9000	475	350
		1	Cold-rolled Steel	10000-15000	1050	735
		2	Cold-rolled Steel	10000-15000	1050	735

Type	Thread Code	Shank Code	Test Sheet Material	Installation (kN)	Pushout (N)	Torque-out (N-m)
S CLS	M2 M2.5 M3	0	5052-H34 Aluminum	6.7-8.9	280	0.9
		1			400	1.13
		2			750	1.47
		0	Cold-rolled Steel		470	1.47
		1			550	1.7
		2			1010	2.03
S CLS	M3.5	0	5052-H34 Aluminum	11.2-13.5	280	1.8
		1			400	1.92
		2			840	2.5
		0	Cold-rolled Steel		480	1.8
		1			570	2.3
		2			1210	2.3
S CLS	M4	0	5052-H34 Aluminum	11.2-13.4	300	2.37
		1			470	2.6
		2			970	4
		0	Cold-rolled Steel		490	2.95
		1			645	4
		2			1250	5.1
SS CLSS	M5	0	5052-H34 Aluminum	11.2-15.6	300	3
		1			480	3.6
		2			845	5.7
		0	Cold-rolled Steel		530	3.6
		1			800	4.5
		2			1112	6.8
S CLS	M6	00	5052-H34 Aluminum	18-32	750	6.5
		0			970	7.9
		1			1580	10.2
		2	14.1			
		00	Cold-rolled Steel		900	10
		0			1380	13
1	1760	17				
2	1760	17				
S CLS	M8	1	5052-H34 Aluminum	18-32	1570	13.6
		2			18.1	
		1	Cold-rolled Steel		1870	18.7
		2			20.3	
S CLS	M10	1	5052-H34 Aluminum	22-36	1760	32.7
		2			36.2	
		1	Cold-rolled Steel		2020	36.2
		2			36.2	
S	M12	1	5052-H34 Aluminum	31-40	2113	39.5
		1	Cold-rolled Steel	44-67	4670	83.1

CLA™ NUTS

Type	Thread Code	Shank Code	Test Sheet Material	Installation (lbs.)	Pushout (lbs.)	Torque-out (in. lbs.)
CLA	440	1	5052-H34 Aluminum	800 - 1500	100	6
		2	5052-H34 Aluminum	800 - 1500	120	9
CLA	632	1	5052-H34 Aluminum	1000 - 1500	110	21
		2	5052-H34 Aluminum	1200 - 1700	155	24
CLA	832	1	5052-H34 Aluminum	1000 - 1500	120	27
		2	5052-H34 Aluminum	1300 - 1800	170	29
CLA	032	1	5052-H34 Aluminum	1700 - 2200	130	34
		2	5052-H34 Aluminum	2600 - 3100	200	50

Type	Thread Code	Shank Code	Test Sheet Material	Installation (kN)	Pushout (N)	Torque-out (N-m)
CLA	M2	2	5052-H34 Aluminum	3.56 - 6.67	500	0.4
		1	5052-H34 Aluminum	3.56 - 6.67	445	0.68
CLA	M3	2	5052-H34 Aluminum	3.56 - 6.67	534	1.02
		1	5052-H34 Aluminum	4.45 - 6.67	534	3.05
CLA	M4	2	5052-H34 Aluminum	5.78 - 8.01	756	3.27

(1) Published installation forces are for general reference. Actual set-up and confirmation of complete installation should be made by observing proper seating of fastener as described in the installation steps. Other performance values reported are averages when all proper installation parameters and procedures are followed. Variations in mounting hole size, sheet material, and installation procedure may affect performance. Performance testing this product in your application is recommended. We will be happy to provide technical assistance and/or samples for this purpose.



SELF-CLINCHING NUTS

PERFORMANCE DATA

S-RT™ NUTS

Type	Thread Code	Shank Code	Test Sheet Material	Installation (lbs.)	Pushout (lbs.)	Torque-out (in. lbs.)
S	RT440	0	5052-H34 Aluminum	1500-2000	63	8
		1			90	10
		2			170	13
		0	Cold-rolled Steel		105	13
		1			125	15
		2			230	18
S	RT632	0	5052-H34 Aluminum	2500-3000	63	16
		1			95	17
		2			190	22
		0	Cold-rolled Steel		110	16
		1			130	20
		2			275	28
S	RT832	0	5052-H34 Aluminum	2500-3000	68	21
		1			105	23
		2			220	35
		0	Cold-rolled Steel		110	26
		1			145	35
		2			285	45
SS	RT032	0	5052-H34 Aluminum	2500-3500	68	26
		1			110	32
		2			190	50
		0	Cold-rolled Steel		120	32
		1			180	40
		2			320	60
S	RT0420	0	5052-H34 Aluminum	4000-7000	220	70
		1			360	90
		2			125	125
		0	Cold-rolled Steel		315	115
		1			400	150
		2				
S	RT0518	1	5052-H34 Aluminum	4000-7000	380	120
		2			160	160
		1			165	165
		2	Cold-rolled Steel		420	180
		1				
		2				

Type	Thread Code	Shank Code	Test Sheet Material	Installation (kN)	Pushout (N)	Torque-out (N-m)
S	RTM3	0	5052-H34 Aluminum	6.7-8.9	280	0.9
		1			400	1.13
		2			750	1.47
		0	Cold-rolled Steel		470	1.47
		1			550	1.7
		2			1010	2.03
S	RTM4	0	5052-H34 Aluminum	11.2-13.4	300	2.37
		1			470	2.6
		2			970	4
		0	Cold-rolled Steel		490	2.95
		1			645	4
		2			1250	5.1
SS	RTM5	0	5052-H34 Aluminum	11.2-15.6	300	3
		1			480	3.6
		2			845	5.7
		0	Cold-rolled Steel		530	3.6
		1			800	4.5
		2			1112	6.8
S	RTM6	00	5052-H34 Aluminum	18-32	750	6.5
		0			970	7.9
		1			1580	10.2
		2	14.1		14.1	
		0	Cold-rolled Steel		900	10
		1			1380	13
2	1760	17				

SL™ NUTS

Thread Code	Shank Code	Prevailing Torque Specifications (1)		Test Sheet Material					
		Max. Torque (1st thru 3rd) (in. lbs.)	Min. Torque (1st thru 3rd) (in. lbs.)	5052-H34 Aluminum			Cold-rolled Steel		
				Installation (lbs.)	Pushout (lbs.)	Torque-out (in. lbs.)	Installation (lbs.)	Pushout (lbs.)	Torque-out (in. lbs.)
440	1	5.75	0.4	1500 - 2000	90	10	2500 - 3500	125	15
	2				170	13		230	18
632	1	10.5	0.8	2500 - 3000	95	17	3000 - 6000	130	20
	2				190	22		275	28
832	1	18	1.2	2500 - 3000	105	23	4000 - 6000	145	35
	2				220	35		285	45
032	1	21	1.65	2500 - 3000	110	32	4000 - 9000	180	40
	2				190	50		250	60
0420	1	35	3.75	4000 - 7000	360	90	6000 - 9000	400	150
	2				360	125		400	150
0518	1	53	4.75	4000 - 7000	380	120	6000 - 8000	420	165
	2				380	160		420	180
0616	1	95	6.3	5000 - 8000	400	270	7000 - 11000	460	320
	2				400	270		460	320

Thread Code	Shank Code	Prevailing Torque Specifications (1)		Test Sheet Material					
		Max. Torque (1st thru 3rd) (N-m)	Min. Torque (1st thru 3rd) (N-m)	5052-H34 Aluminum			Cold-rolled Steel		
				Installation (kN)	Pushout (N)	Torque-out (N-m)	Installation (kN)	Pushout (N)	Torque-out (N-m)
M3	1	0.67	0.04	6.7 - 8.9	400	1.13	11.2 - 15.6	550	1.7
	2				750	1.47		1010	2.03
M3.5	1	1.2	0.08	11.2 - 13.5	400	1.92	13.4 - 26.7	570	2.3
	2				840	2.5		1210	2.3
M4	1	2.1	0.13	11.2 - 13.4	470	2.6	18 - 27	645	4
	2				970	4		1250	5.1
M5	1	2.4	0.18	11.2 - 15.6	480	3.6	18 - 38	800	4.5
	2				845	5.7		1112	6.8
M6	1	4	0.3	18 - 32	1580	10.2	27 - 36	1760	17
	2				1580	14.1		1760	17
M8	1	6	0.5	18 - 32	1570	13.6	27 - 36	1870	18.7
	2				1570	18.1		1870	20.3
M10	1	12	0.8	22 - 36	1760	32.7	32 - 50	2020	36.2
	2				1760	32.7		2020	36.2

(1) 3 cycle locking performance. Max. on / Min. off torque for 1st through 3rd cycles.



SELF-CLINCHING NUTS

PERFORMANCE DATA

SP™ NUTS

UNIFIED	Type	Thread Code	Shank Code	Test Sheet Material	Installation (lbs.)	Pushout (lbs.)	Torque-out (in. lbs.)
	SP	256	0	304 Stainless Steel	8000	130	14
			1		9000	165	17
			2		10000	290	18
	SP	440	0	304 Stainless Steel	8000	130	14
			1		9000	165	17
			2		10000	290	18
	SP	632	0	304 Stainless Steel	8500	140	18
			1		9500	170	24
			2		10500	340	28
SP	832	0	304 Stainless Steel	9000	145	30	
		1		10000	180	37	
		2		11000	360	45	
SP	024/032	0	304 Stainless Steel	9500	180	35	
		1		10500	230	45	
		2		11500	400	60	
SP	0420	1	304 Stainless Steel	13500	450	150	
		2		13500	600	170	
SP	0518	1	304 Stainless Steel	14800	470	170	
		2		14800	750	250	
SP	0524	1	304 Stainless Steel	14800	470	170	
		2		14800	750	250	
SP	0616/0624	1	304 Stainless Steel	16000	600	300	
		2		20000	700	370	

METRIC	Type	Thread Code	Shank Code	Test Sheet Material	Installation (kN)	Pushout (N)	Torque-out (N-m)
	SP	M2	1	304 Stainless Steel	40	725	1.92
			2		44.5	1290	2.03
	SP	M2.5	0	304 Stainless Steel	35.6	575	1.58
			1		40	725	1.92
			2		44.5	1290	2.03
	SP	M3	0	304 Stainless Steel	35.6	575	1.58
			1		40	725	1.92
			2		44.5	1290	2.03
	SP	M4	0	304 Stainless Steel	40	645	3.38
1			44.5		800	4.18	
2			49		1600	5.08	
SP	M5	0	304 Stainless Steel	42.3	800	3.95	
		1		46.7	1025	5.08	
		2		51.2	1775	6.77	
SP	M6	1	304 Stainless Steel	60	2000	17	
		2		60	2600	19	
SP	M8	1	304 Stainless Steel	66	2100	19	
		2		80	4500	23	
SP	M10	1	304 Stainless Steel	80	2150	38	

H™ NUTS

UNIFIED	Type	Thread Code	Test Sheet Thickness and Sheet Material	Installation (lbs.)	Pushout (lbs.)	Torque-out (in. lbs.)
	H	0616	.090" 5052-H34 Aluminum	4900	380	190
		.088" Cold-rolled Steel	7400	460	240	

METRIC	Type	Thread Code	Test Sheet Thickness and Sheet Material	Installation (kN)	Pushout (N)	Torque-out (N-m)
	H	M10	2.29 mm 5052-H34 Aluminum	22	1760	21.5
2.24 mm Cold-rolled Steel			33	2020	27.1	

SH™ NUTS

UNIFIED	Thread Code	Shank Code	Test Sheet Thickness and Material (in.)	Sheet Hardness HRC	Installation (lbs.)	Pushout (lbs.)	Torque-out (in. lbs.)
	0420	1	.098" S700MC	23	11700	950	150
		2	.098" S700MC	23	12900	1000	170
	0518	1	.098" S700MC	23	12600	1050	265
		2	.098" S700MC	23	12900	1100	265
0616	1	.098" S700MC	23	15300	1200	500	

METRIC	Thread Code	Shank Code	Test Sheet Thickness and Material (mm)	Sheet Hardness HRC	Installation (kN)	Pushout (N)	Torque-out (N-m)
	M6	1	2.5 mm S700MC	23	52.1	4200	17
		2	2.5 mm S700MC	23	57.4	4500	19
	M8	1	2.5 mm S700MC	23	56.1	4600	30
		2	2.5 mm S700MC	23	57.4	4900	30
M10	1	2.5 mm S700MC	23	71.2	5400	56	



SELF-CLINCHING NUTS

PERFORMANCE DATA

SMPS™ NUTS

UNIFIED	Type	Thread Code	Test Sheet Material		
			Cold-rolled Steel		
			Installation (lbs.)	Pushout (lbs.)	Torque-out (in. lbs.)
SMPS	256	1500	35	8	
SMPS	440	1800	60	12	
SMPS	632	2000	65	14	

METRIC	Type	Thread Code	Test Sheet Material		
			Cold-rolled Steel		
			Installation (kN)	Pushout (N)	Torque-out (N-m)
SMPS	M2.5	6.7	156	1.13	
SMPS	M3	8	267	1.35	
SMPS	M3.5	8.8	289	1.58	

SMPP™ NUTS

UNIFIED	Thread Code	Max. Tightening Torque (in. lbs.) (1) (2)	Test Sheet Thickness and Material (in.)	Sheet Hardness HRB	Installation (lbs.) (3)	Pushout (lbs.)	Torque-out (in. lbs.)	Tensile Strength (lbs.) (1) (2)	Test Bushing Hole Size For Pull Thru Tests (in.)
440	13	.029" 304 Stainless Steel	89	4500	75	15	850	.112	
632	20	.029" 304 Stainless Steel	89	6000	75	20	1020	.138	

METRIC	Thread Code	Max. Tightening Torque (N-m) (1) (2)	Test Sheet Thickness and Material (mm)	Sheet Hardness HRB	Installation (kN) (3)	Pushout (N)	Torque-out (N-m)	Tensile Strength (kN) (1) (2)	Test Bushing Hole Size For Pull Thru Tests (mm)
M3	1.5	0.7 mm 304 Stainless Steel	89	20	300	1.85	3.63	3.5	
M3.5	2.1	0.7 mm 304 Stainless Steel	89	27	300	1.9	4.25	4	

- (1) Head size is adequate to ensure failure in threaded area when tested with industry standard tensile bushing diameter.
- (2) Tightening torque shown will induce preload of 70% of minimum axial strength assuming K or nut factor is equal to 0.20. In some applications tightening torque may need to be adjusted based on the actual K value. All tightening torques shown are based on 180 ksi/ Property Class 12.9 screws. For lower strength screws the tightening torque is proportionately less. For example, for 120 ksi screws, torque is 67% of value shown. For 900 MPa screws (Property Class 9.8) torque value is 74% of value shown.
- (3) Installation controlled by proper cavity depth in installation tooling.

PUSHOUT TEST

Pushout tests shall be performed from the grip or shank side of the installed fastener. An axial load shall be applied to the fastener as shown using a hardened test screw, while evenly supporting the test strip around the fastener. The typical position rate is .25" / 6.35 mm per minute. Dimensions are identified per PEM Bulletins where "E" equals head diameter and "T" (or "L") equals head height. The pushout force is measured using a force or compression tester with a range that will cover the expected forces.

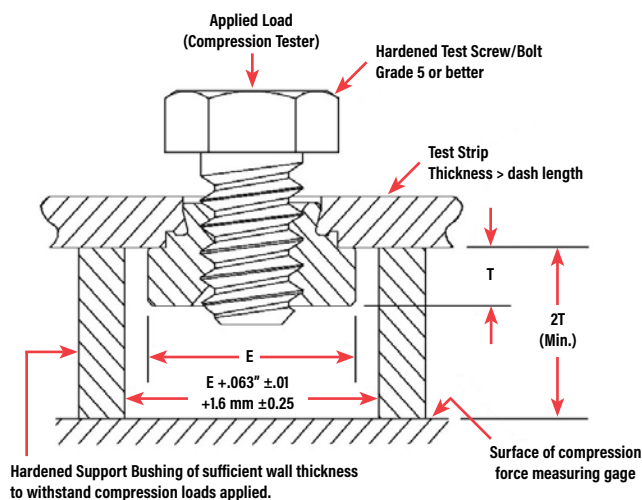

TORQUE-OUT TEST

Torque-out tests shall be performed from the shoulder or head side of the installed fastener. Torque shall be applied to the fastener in the manner illustrated, using a hardened test screw and washer, while firmly holding the test strip. Test screws should be of sufficient tensile strength to resist thread stripping. A minimum of two screw threads must extend beyond the fastener.

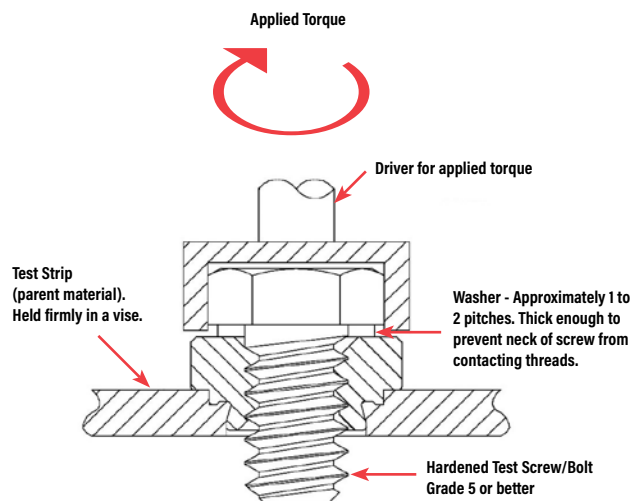

SELF-PIERCING, SELF-CLINCHING TOOLING

Specialized PEMSERTER® tooling allows installation of S self-clinching nuts into aluminum sheets (sizes 1/4", 5/16", M6 and M8) in one pierce/press operation.

For more information, see our web site for Tech Sheet PEM® - Ref / Self-piercing, self-clinching tooling.
To locate, simply type "self-piercing" in site search box.

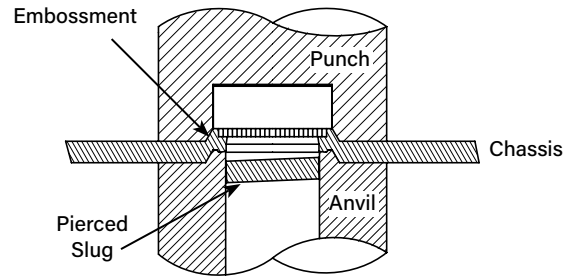

SELF-CLINCHING NUT INSTALLATION DOS AND DON'TS

"DOS"

- DO** select the proper fastener material to meet corrosion requirements.
- DO** make certain that panel material is in the annealed condition.
- DO** make certain that hole punch is kept sharp to minimize work hardening around hole.
- DO** provide mounting hole of specified size for each fastener.
- DO** maintain the hole punch diameter to no greater than $+.001"/.025$ mm over the minimum recommended mounting hole for type SP nuts into stainless steel sheets.
- DO** install fastener into hole punch side of sheet.
- DO** make certain that shank (or pilot) is within hole before applying installation force.
- DO** make certain that fastener is not installed adjacent to bends or other highly cold-worked areas.
- DO** apply squeezing force between parallel surfaces.
- DO** utilize recommended installation tooling when installing fasteners.
- DO** apply sufficient force to totally embed clinching ring around entire circumference and to bring shoulder squarely in contact with sheet.

"DON'TS"

- DON'T** attempt to install any self-clinching nut other than types SP/SMPP fasteners into a stainless steel sheet.
- DON'T** install steel or stainless steel fasteners in aluminum panels before anodizing or finishing.
- DON'T** deburr mounting holes on either side of sheet before installing fasteners – deburring will remove metal required for clinching fastener into sheet.
- DON'T** install fastener closer to edge of sheet than minimum edge distance indicated by manufacturer – unless a special fixture is used to restrict bulging of sheet edge.
- DON'T** over-squeeze. It will crush the head, distort threads, and buckle the sheet. Approximate installation forces are listed in performance data tables. Use this info as a guide. Be certain to determine optimum installation force by test prior to production runs.
- DON'T** attempt to insert fastener with a hammer blow – under any circumstances. A hammer blow won't permit the sheet metal to flow and develop an interlock with the fastener's contour.
- DON'T** install screw in the head side of fastener. Install from opposite side so that the fastener load is toward sheet. The clinching force is designed only to hold the fastener during handling and to resist torque during assembly.
- DON'T** install fastener on pre-painted side of panel.

All PEM® products meet our stringent quality standards. If you require additional industry or other specific [quality certifications](#), special procedures and/or part numbers are required. Please contact your local sales office or representative for further information.

Regulatory [compliance information](#) is available in Technical Support section of our website. Specifications subject to change without notice. See our website for the most current version of this bulletin.

PennEngineering®



CL-16

North America: Danboro, Pennsylvania USA • E-mail: info@pemnet.com • Tel: +1-215-766-8853 • 800-237-4736 (USA)

Europe: Galway, Ireland • E-mail: europa@pemnet.com • Tel: +353-91-751714

Asia/Pacific: Singapore • E-mail: singapore@pemnet.com • Tel: +65-6-745-0660

Shanghai, China • E-mail: china@pemnet.com • Tel: +86-21-5868-3688

Visit our PEMNET™ Resource Center at www.pemnet.com • Technical support e-mail: techsupport@pemnet.com